

IPF COLASIT PLASTIC FANS

- Corrosion Resistant • In-Line or Roof Configuration • Fire Retardant PPs

To select the appropriate fan for your application, use the performance tables to locate the model that provides the CFM required at the static pressure specified. For highest efficiency, select the fan size that will handle the required capacity and pressure with the lowest horsepower motor.

Model CRDV Performance Table

Model CRDV	Inlet/Outlet	RPM	H.P.	CFM @ Static Pressure (W.G.)													
				.40	.80	1.00	1.20	1.60	2.00	2.40	2.80	3.00	3.20	3.60	4.00		
180	7"	1725 3450	3/4 2	650	400	200	120										
200	8"	1140 1725	1/2 3/4	600	100	1000	880	410									
225	9"	1140 1725	3/4	100	530	1400	1240	1030	440								
250	10"	1140 1725	1/2 2		1100	900	300	1800	1500	1030							
280	11"	1140 1725	1 5		1650	1500	1100	2750	2600	2350	1880	1350	880				
315	12"	1140 1725	2 5		2000	1700	1300	600 2950	2400	2000	1470	1200	880	300			

Dimensions

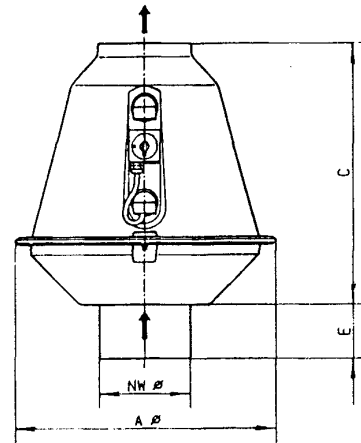
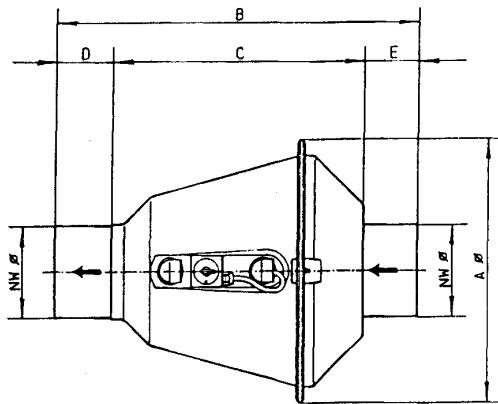

CRDV	180/200 200/200	225/250 250/250	280/315 315/315
NW	7.87"	9.84"	12.40"
A	22.64"	25.00"	27.76"
B	29.92"	30.51"	31.54"
C	21.97"	22.56"	23.58"
D	4.92"	6.69"	8.66"
E	4.61"	6.38"	8.35"